

Order Quotation

Invoicing Details	Shipping Details
Company name: _____ Delivery date required: ___ / ___ / ___ Delivery address: _____ P.Code: _____ Town: _____ Tel.: _____ Fax: _____ # Order: _____ Date of the order: ___ / ___ / ___	Ship to: _____ _____ <p style="text-align: center;">CUSTOMER STAMP AND SIGNATURE</p>

Pro Medicare srl grants **24 months** warranty on production defects from the date of the first put into service and **12 months** on covers and components subjected to wearing. Warranty is void if the product is used in any other way than stated in the Instruction Manual.

Note: Any request for variation in dimensions, materials and type compared to the standard does not have **CE** marking, therefore the professional user becomes the manufacturer and has the obligation to draw up the technical documentation of the device (this is valid for the sections of the sheet with the letter **W**).

Images are purely illustrative and may not fully reflect reality.

Specifications of the wheelchair on which to install the Versa System

<input type="checkbox"/> on Adacta Frame Model _____ Size _____ Serial number (in case of renewal) _____			
<input type="checkbox"/> on other manufacturer frame			
AB = _____ (outside tubes)		Seat tube diameter	<input type="checkbox"/> 20 <input type="checkbox"/> 22 <input type="checkbox"/> 25
CD = _____		Backrest tube diameter <i>upper part</i>	<input type="checkbox"/> 20 <input type="checkbox"/> 22 <input type="checkbox"/> 25
EF = _____ (outside tubes)		Backrest tube diameter <i>lower part</i>	<input type="checkbox"/> 20 <input type="checkbox"/> 22 <input type="checkbox"/> 25
DF = _____		<input type="checkbox"/> AD KIT for seat (if round tube)	<i>Example of an adaptability kit</i>
DG = _____		<input type="checkbox"/> AD KIT for backrest (if round tube)	
<p>NOTE: In case of orders of non-standard Versa Positioning Systems to be mounted on other brand wheelchairs the AD KIT (tracks, clamps and collars) is not needed when all the required measures are filled in the form. In case of orders of standard Versa Positioning Systems, then it is necessary to buy the AD KIT.</p>			
<input type="checkbox"/> on power wheelchair			
AB = _____ (outside tubes)		Seat tube diameter	<input type="checkbox"/> 20 <input type="checkbox"/> 22 <input type="checkbox"/> 25
CD = _____		Backrest tube diameter <i>upper part</i>	<input type="checkbox"/> 20 <input type="checkbox"/> 22 <input type="checkbox"/> 25
EF = _____ (outside tubes)		Backrest tube diameter <i>lower part</i>	<input type="checkbox"/> 20 <input type="checkbox"/> 22 <input type="checkbox"/> 25
DF = _____		<input type="checkbox"/> AD KIT for seat (if round tube)	<i>Example of an adaptability kit</i>
DG = _____		<input type="checkbox"/> AD KIT for backrest (if round tube)	
<p>NOTE: In case of orders of non-standard Versa Positioning Systems to be mounted on power wheelchair with round tubes the AD KIT (tracks, clamps and collars) is not needed when we receive the wheelchair with freight paid by the sender. When the power wheelchair has square tube section and Versa Positioning Systems are not standard the purchase of additional tubes for mounting operations is needed. In case of orders of standard Versa Positioning Systems, then it is necessary to buy the AD KIT (tracks, clamps and collars) either on square and round tube sections.</p>			
<input type="checkbox"/> on wheelchair certified for transportation in a vehicle			
Backrest mounting hardware with 4 securing clamps - Seat mounting hardware with 2 securing clamps and 2 interlocking clamp (Note: It is strictly advised the use of a headrest correctly positioned)			
<input type="checkbox"/> Lateral tilt			
<input type="checkbox"/> RH	_____ (cm)	right side higher	
<input type="checkbox"/> LH	_____ (cm)	left side higher	
<p>NOTE: The quotation and realization of the lateral tilt will be done only if all measurements as well as the weight of the patient are correctly reported. The lateral tilt is available only on ADACTA-VERSA combination.</p>			

DETECTION OF ALL MEASUREMENTS

The following measurements* will be taken in supine position:

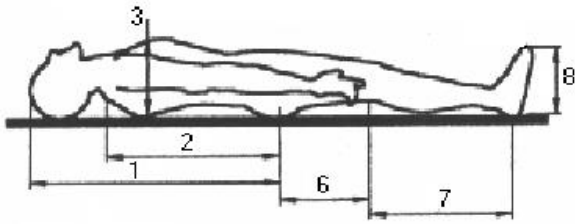

	LH side	RH side
1		
2		
3		
6		
7		
8		
H		
Head circumference (cm)		
Weight (kg)		

The following measurements* will be taken in sitting position:

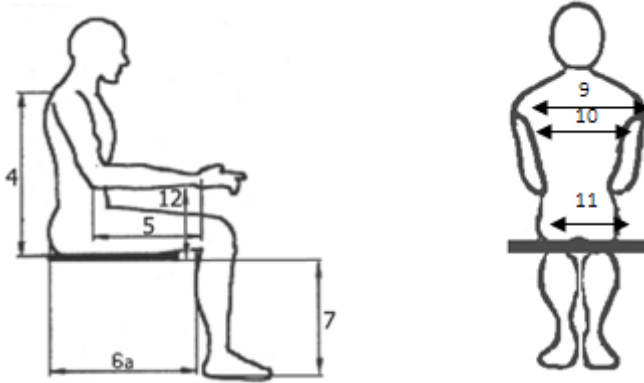

	LH side	RH side
4		
5		
6a		
7		
9		
10		
11		
12		

*GUIDELINES FOR THE DETECTION OF PATIENT'S MEASUREMENTS

1	Measurement from the greater trochanter to the head
2	Measurement from the greater trochanter to the apex of the shoulders
3	Depth of the thorax (useful for the length of the thoracic supporting pads)
4	Distance from the plane of the seat to the shoulders
5	Length of the forearm (elbow-wrist measurement useful for the armrest length)
6	Measurement from the greater trochanter to the popliteal space
6a	Distance from the backrest plane to the popliteal space (useful for the depth of the seat)
7	Measurement from the popliteal space to the heel (useful for the footrests height)
8	Length of the feet
9	Width of the shoulders (useful for the width of the backrest)
10	Width of the thorax (useful for the width adjustments of the thoracic supports)
11	Width of the pelvis (useful for the width of the seat)
12	Distance from the armrest to the seat (useful for the height of the armrest)
Weight	(Useful for the barycentre)

SEAT

 with wooden base and attachments

 removable from the wooden seat base
(seat construction base made of polyethylene foam; no attachments)

1. Specify the shape

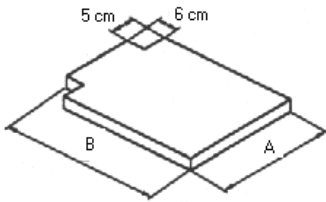
 Standard seat shape

Note: can be combined with all padding

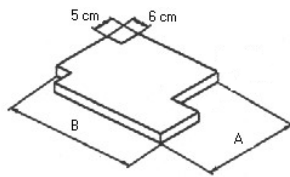
 Asymmetric seat shape

Note: can be combined with all padding except for the foam in place

Padding shape

Indicare:

B right side

B left side

 Hip dislocation

 Pelvic rotation

 Anterior split seat shape

Indicate the length of the cut

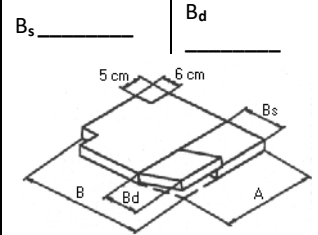

Note: can be combined with the flat padding only

2. Specify the size

	<input type="checkbox"/> US	<input type="checkbox"/> XXS	<input type="checkbox"/> XS	<input type="checkbox"/> XS1	<input type="checkbox"/> S	<input type="checkbox"/> M	<input type="checkbox"/> M1	<input type="checkbox"/> L	<input type="checkbox"/> XL	<input type="checkbox"/> W
A Width	30 <small>(from 20 to 30)</small>	36 <small>(from 26 to 36)</small>	36 <small>(from 26 to 36)</small>	39 <small>(from 29 to 39)</small>	42 <small>(from 32 to 42)</small>	42 <small>(from 32 to 42)</small>	45 <small>(from 35 to 45)</small>	48 <small>(from 38 to 48)</small>	48 <small>(from 38 to 48)</small>	
B Depth	38 <small>(from 32 to 38)</small>	38 <small>(from 32 to 38)</small>	42 <small>(from 36 to 42)</small>	44 <small>(from 38 to 44)</small>	44 <small>(from 38 to 44)</small>	50 <small>(from 44 to 50)</small>	50 <small>(from 44 to 50)</small>	44 <small>(from 38 to 44)</small>	50 <small>(from 44 to 50)</small>	

NOTE: The values between brackets are referred to the minimum and maximum adjustments of the width by using the "B" type bracket, and the adjustments of the depth through the notches on the seat. (SEE THE BRACKETS TABLE). All measurements are expressed in centimeters.

3. Specify the padding

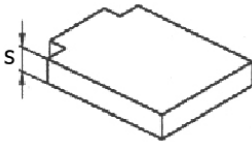
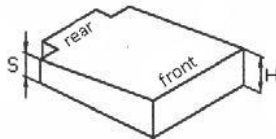
 Flat

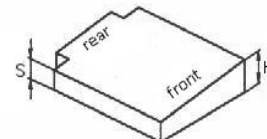
 Wedge

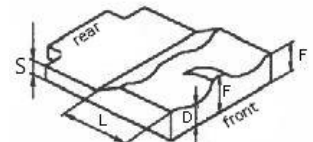
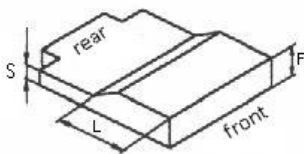
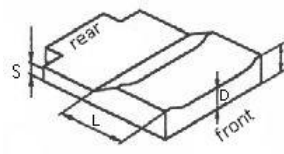
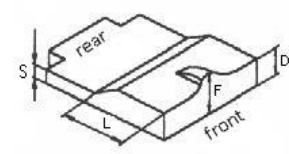
 anterior
 posterior

 Lateral wedge

 right
 left

 Anatomic

 Anti-thrust

 Anti-thrust with adductor

 Anti-thrust with abductor

4. Indicate the type of fixing of the wedges to the seat

 glue

 hook and loop

Shape of the multi-adjustable wooden seat base with SKY cover:

(the mounting hardware is included; for the size/dimensions of the standard/asymmetric wooden seat base, please, fill the the form regarding the shape and the size of the seat)

 Standard

 Asimmetric

SEAT PADDING CUSTOMIZATIONS

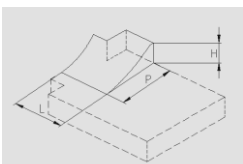
 Posterior wedge/Lateral hip support

H _____

P _____

L _____

 right

 left

 fixed

 removable

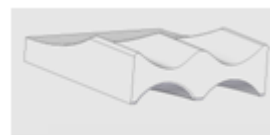
 Front notches for flexed knees

 right

 left

 Depth adjustment of the pre-ischial block (Only for anti-thrust and anatomic padding)

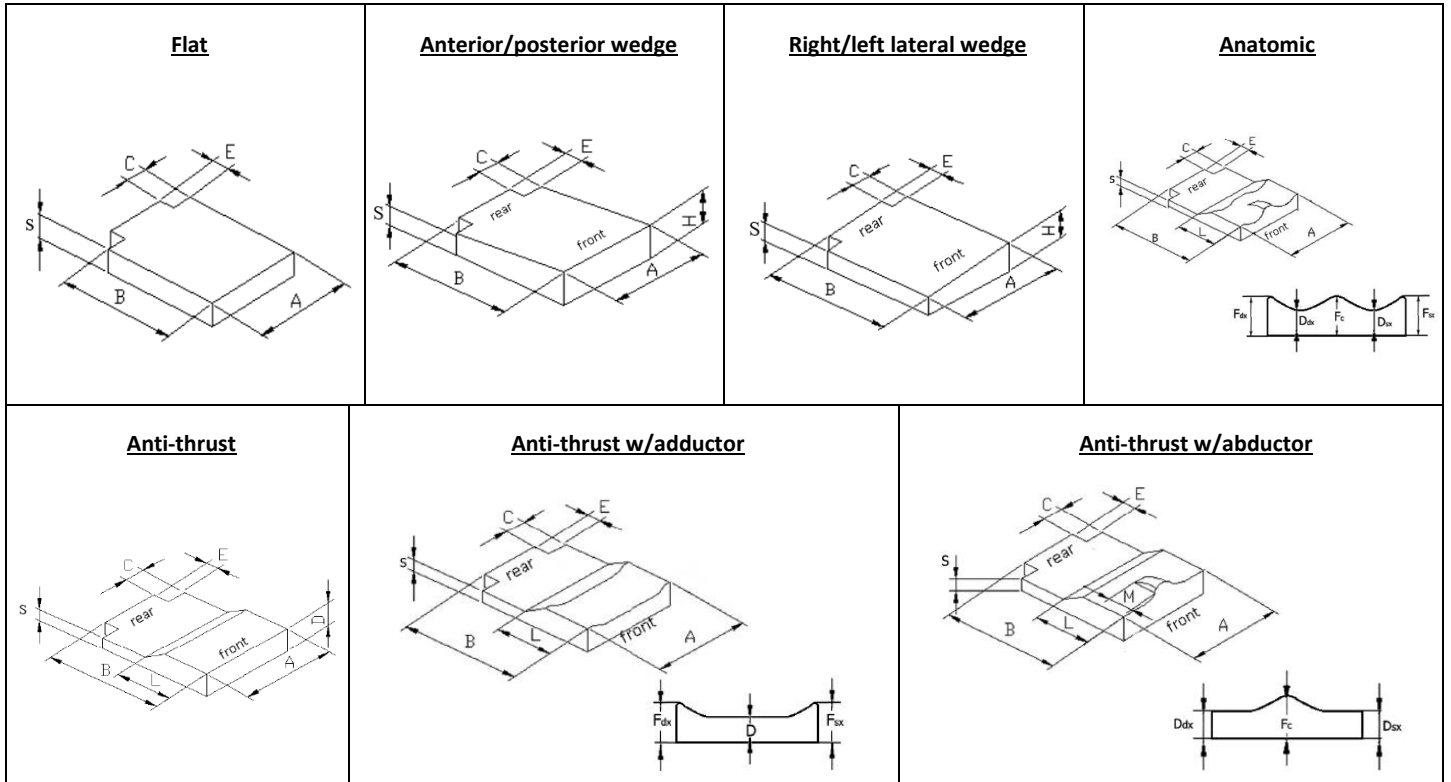
SEAT PADDINGS



Characteristic Dimensions of the seats (expressed in cm)

Note: the below sizes and dimensions are referred to the finished product including the padding

Misure	US	XXS	XS	XS1	S	M	M1	L	XL
A	30	36	36	39	42	42	45	48	48
B	38	38	42	44	44	50	50	44	50
C	5	5	5	5	5	5	5	5	5
D	9	9.5	9.5	9.5	12.5	12.5	12.5	12.5	12.5
D _{RH}	9	9.5	9.5	9.5	12.5	12.5	12.5	12.5	12.5
D _{LH}	9	9.5	9.5	9.5	12.5	12.5	12.5	12.5	12.5
E	6	6	6	6	6	6	6	6	6
F _C	13	14	14	14	17	17	17	17	17
F _{RH}	13	14	14	14	17	17	17	17	17
F _{LH}	13	14	14	14	17	17	17	17	17
L	16	16	18	19	19	24	24	19	24
M	10	11	12	13	13	15.5	15.5	13	15.5
S	6	6	6	6	8	8	8	8	8
H	8	8.5	8.5	11	11	12	12	11	12

Report the difference of value with respect to the standard shown above (W)

A = _____	F _C = _____	<p style="text-align: center;">Standard Padding type and thickness</p>	from US to XS1	from S to XL	
B = _____	F _{RH} = _____		4 Breathable Foam	1 cm	1 cm
C = _____	F _{LH} = _____		3 Antidecubitus foam	3 cm	4 cm
D = _____	L = _____		2 Bearing foam	2 cm	3 cm
D _{RH} = _____	M = _____		1 Plywood/ Polyethylene foam	1.2/1.5 cm	1.2/1.5 cm
D _{LH} = _____	S = _____				
E = _____					

BACKREST

 with wooden base and attachments

 removable from the wooden seat base

(backrest construction base made of polyethylene foam; no attachments)

1. Specify the shape

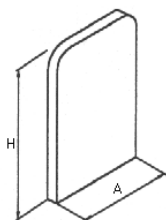
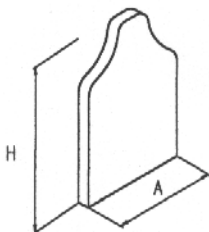
 Standard backrest shape

 Scapular cut-outs backrest shape

 I or C backrest shape

 I

 C (please, fill in the side of interest only)

	RH side	LH side
D		
T		
A		
E		

Note: Can be combined with all padding

Note: Can be combined with all padding except the foam in place

Note: Can be combined with all padding

2. Indicate the position of the headrest mounting holes

 standard

 not centred

 on the right
 on the left

3. Specify the size

	<input type="checkbox"/> US	<input type="checkbox"/> XXS	<input type="checkbox"/> XS	<input type="checkbox"/> XS1	<input type="checkbox"/> S	<input type="checkbox"/> M	<input type="checkbox"/> M1	<input type="checkbox"/> L	<input type="checkbox"/> W
A Width	30 <small>(from 20 to 30)</small>	36 <small>(from 26 to 36)</small>	36 <small>(from 26 to 36)</small>	39 <small>(from 29 to 39)</small>	42 <small>(from 32 to 42)</small>	42 <small>(from 32 to 42)</small>	45 <small>(from 35 to 45)</small>	48 <small>(from 38 to 48)</small>	
H height	38 <small>(from 38 to 46)</small>	38 <small>(from 38 to 46)</small>	42 <small>(from 42 to 48)</small>	46 <small>(from 46 to 52)</small>	46 <small>(from 46 to 52)</small>	50 <small>(from 50 to 56)</small>	52 <small>(from 52 to 58)</small>	50 <small>(from 50 to 56)</small>	

NOTE: The values between brackets are referred to the minimum and maximum adjustments of the width by using the "B" type brackets, and the adjustment of the height by sliding the backrest attaching hardware on the back canes. (SEE THE BRACKETS TABLE). All measurements are expressed in centimeters.

4. Specify the padding

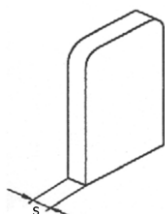
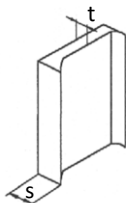
 Flat

 Contoured

 Foam in place pre-arranged backrest (W)

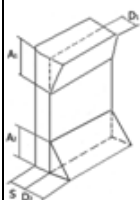
 soft
 medium
 semi-rigid

Backrest padding customizations (W)

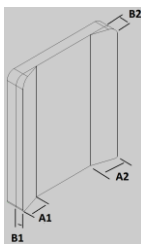
 Superior/inferior wedge

 Superior

 $A_1 = \text{___}$ $D_1 = \text{___}$
 Inferior

 $A_2 = \text{___}$ $D_2 = \text{___}$
 Right/Left wedge

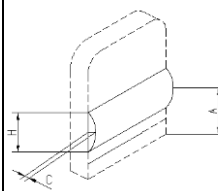
 right

 $A_1 = \text{___}$
 $B_1 = \text{___}$
 left

 $A_2 = \text{___}$
 $B_2 = \text{___}$
 Lumbar Support

 Indicate if: removable fixed

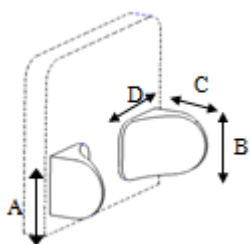
cm	<input type="checkbox"/> XXS	<input type="checkbox"/> XS	<input type="checkbox"/> M	<input type="checkbox"/> W
C	2	2	2.5	
H	9	11	12	

Indicate the distance from the bottom of the backrest to lumbar support maximum pushing point: A _____

 Lumbar contoured customised wedges (please indicate the size and the type of wedge)

cm	RH	LH
A		
B		
C		
D		

 Lumbar containment insert
 RH side LH side

 Lumbar pushing insert
 RH side LH side



A: positioning wedge from his superior border to backrest's inferior; B: height; C: depth; D: width

5. Indicate the type of fixing of the wedges to the backrest

 glue

 hoop and loop

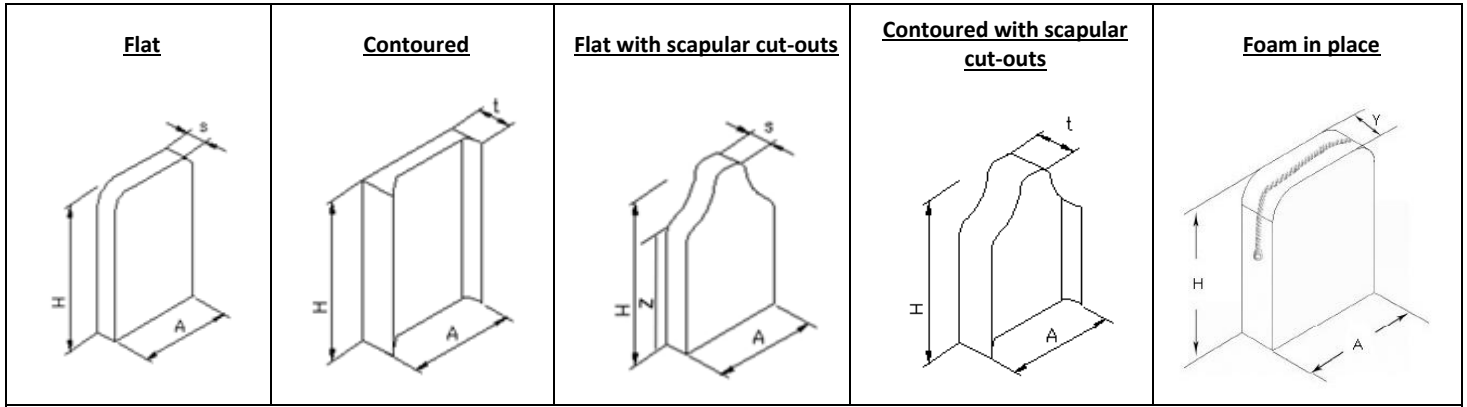
BACKREST PADDINGS



Characteristic dimensions of the backrests (in cm)

Note: The below sizes and dimensions are referred to the finished product including the padding

Sizes	US	XXS	XS	XS1	S	M	M1	L
A	30	36	36	39	42	42	45	48
H	38	38	42	46	46	50	52	50
S	5	5	5	5	6	6	6	6
T	7.5	7.5	8	9	9	9	9	9
Y	15	15	15	17	17	17	17	17
Z	25	25	27	29	29	33	35	33

Report the difference of value with respect to the standard above (W)

A = _____	Standard Padding types and thickness 	From US to XS1	From S to XL	Padding types and thickness only for foam in place backrest 	From US to XS1	From S to XL
H = _____		3 Breathable foam	1 cm		1 cm	3 Breathable foam
T = _____	2 Antidecubitus foam	3 cm	4 cm	2 Antidecubitus foam	3 cm	4 cm
S = _____	1 Plywood/ Polyethylene foam	1.2/1.5 cm	1.2/1.5 cm	1 Plywood	1.2/1.5 cm	1.2/1.5 cm
Z = _____	Note: the breathable foam is stitched into the lining					

Note: to personalize W please make a drawing

Please, indicate the type, fabric and color of the cover

Type (T):

- 1)** with staples (not removable)
2) removable with elastic
3) removable with H&L
4) removable with/zip

Fabric and color of the cover (M):

- | | | |
|--|--|--|
| A) Leather Flex Black (code 901) | F) Leather Flex Ocean (code 915) | M) Neoprene - Lycra wine (code 107) |
| B) Neoprene - Lycra Black (code 101) | G) Neoprene - Lycra Royal (code 103) | N) Neoprene - Lycra scarlet (code 108) |
| C) Perforated - Lycra Black (code 201) | H) Neoprene - Lycra Turquoise (code 104) | O) Perforato - Nylon Royal (code 109 RY) |
| D) Neoprene - Lycra Navy (code 102) | I) Neoprene - Nylon Green (code 505) | |
| E) Perforated - Nylon Green (code 105) | L) Neoprene - Lycra Violet (code 106) | |

Please, indicate the combination: (i.e. seat:1-A Type (1): with staples; Fabric and color of the cover (A): Leather Flex Black code 901)

Seat (T-M): _____



Backrest (T-M): _____

Accessories (T-M): _____ (The covers removable with zip or with H&L are not available on accessories)

Note: For contoured padding it is not recommended the use of leather flex fabric because it is not elasticised; for Foam in place pre-arranged backrest it is not recommended the cover removable with elastic

VERSA POSITIONING SYSTEM ACCESSORIES

HEAD positioning system Versa Capitis

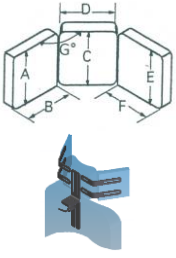
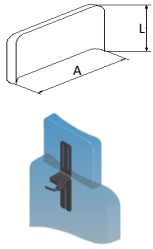
<input type="checkbox"/> Anatomic  Size <input type="checkbox"/> XP <input type="checkbox"/> P <input type="checkbox"/> M <input type="checkbox"/> G <input type="checkbox"/> long horizontal bar <input type="checkbox"/> short horizontal bar Note: Detachable mounting hardware included	<input type="checkbox"/> Confort  Size <input type="checkbox"/> P <input type="checkbox"/> M <input type="checkbox"/> G <input type="checkbox"/> long horizontal bar <input type="checkbox"/> short horizontal bar Note: Detachable mounting hardware included	<input type="checkbox"/> Versa 3 pads headrest (W)  A _____ B _____ C _____ D _____ E _____ F _____ G° _____ Note: Standard G = 120°	<input type="checkbox"/> Versa backrest extension (W)  Indicate: <input type="checkbox"/> top <input type="checkbox"/> bottom <input type="checkbox"/> flat <input type="checkbox"/> contoured L = 15 cm A = backrest width
---	--	---	---

Thoracic supports

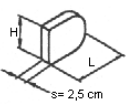
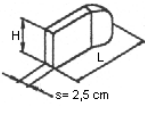
<input type="checkbox"/> Flat pad  <table border="1" style="width: 100%; border-collapse: collapse;"> <thead> <tr> <th>Size (cm)</th> <th>XS</th> <th>S</th> <th>M</th> <th>L</th> <th>W_{RH}</th> <th>W_{LH}</th> </tr> </thead> <tbody> <tr> <td>H</td> <td>8</td> <td>10</td> <td>12</td> <td>12</td> <td></td> <td></td> </tr> <tr> <td>L</td> <td>10</td> <td>12</td> <td>15</td> <td>18</td> <td></td> <td></td> </tr> </tbody> </table> <table border="1" style="width: 100%; border-collapse: collapse;"> <thead> <tr> <th>Side</th> <th>Pad Shape</th> <th>Bracket Type</th> <th>Bracket Shape</th> <th>Size</th> </tr> </thead> <tbody> <tr> <td rowspan="2">RH</td> <td><input type="checkbox"/> linear <input type="checkbox"/> armpit cut</td> <td><input type="checkbox"/> fixed <input type="checkbox"/> detachable <input type="checkbox"/> swing-away</td> <td><input type="checkbox"/> A <input type="checkbox"/> B <input type="checkbox"/> C <input type="checkbox"/> D</td> <td></td> </tr> <tr> <td><input type="checkbox"/> linear <input type="checkbox"/> armpit cut</td> <td><input type="checkbox"/> fixed <input type="checkbox"/> detachable <input type="checkbox"/> swing-away</td> <td><input type="checkbox"/> A <input type="checkbox"/> B <input type="checkbox"/> C <input type="checkbox"/> D</td> <td></td> </tr> <tr> <td colspan="2">Bracket padding <input type="checkbox"/> RH <input type="checkbox"/> LH</td> <td colspan="3">Bracket dimensions <input type="checkbox"/> short <input type="checkbox"/> long</td> </tr> </tbody> </table>	Size (cm)	XS	S	M	L	W _{RH}	W _{LH}	H	8	10	12	12			L	10	12	15	18			Side	Pad Shape	Bracket Type	Bracket Shape	Size	RH	<input type="checkbox"/> linear <input type="checkbox"/> armpit cut	<input type="checkbox"/> fixed <input type="checkbox"/> detachable <input type="checkbox"/> swing-away	<input type="checkbox"/> A <input type="checkbox"/> B <input type="checkbox"/> C <input type="checkbox"/> D		<input type="checkbox"/> linear <input type="checkbox"/> armpit cut	<input type="checkbox"/> fixed <input type="checkbox"/> detachable <input type="checkbox"/> swing-away	<input type="checkbox"/> A <input type="checkbox"/> B <input type="checkbox"/> C <input type="checkbox"/> D		Bracket padding <input type="checkbox"/> RH <input type="checkbox"/> LH		Bracket dimensions <input type="checkbox"/> short <input type="checkbox"/> long			<input type="checkbox"/> Contoured pad  <table border="1" style="width: 100%; border-collapse: collapse;"> <thead> <tr> <th>Size (cm)</th> <th>XS</th> <th>S</th> <th>M</th> <th>W_{RH}</th> <th>W_{LH}</th> </tr> </thead> <tbody> <tr> <td>H</td> <td>8</td> <td>10</td> <td>12</td> <td></td> <td></td> </tr> <tr> <td>L</td> <td>14</td> <td>16</td> <td>19</td> <td></td> <td></td> </tr> </tbody> </table> <table border="1" style="width: 100%; border-collapse: collapse;"> <thead> <tr> <th>Side</th> <th>Pad Shape</th> <th>Bracket Type</th> <th>Bracket Shape</th> <th>Size</th> </tr> </thead> <tbody> <tr> <td rowspan="2">RH</td> <td><input type="checkbox"/> linear <input type="checkbox"/> armpit cut</td> <td><input type="checkbox"/> fixed <input type="checkbox"/> detachable <input type="checkbox"/> swing-away</td> <td><input type="checkbox"/> A <input type="checkbox"/> B <input type="checkbox"/> C <input type="checkbox"/> D</td> <td></td> </tr> <tr> <td><input type="checkbox"/> linear <input type="checkbox"/> armpit cut</td> <td><input type="checkbox"/> fixed <input type="checkbox"/> detachable <input type="checkbox"/> swing-away</td> <td><input type="checkbox"/> A <input type="checkbox"/> B <input type="checkbox"/> C <input type="checkbox"/> D</td> <td></td> </tr> <tr> <td colspan="2">Bracket padding <input type="checkbox"/> RH <input type="checkbox"/> LH</td> <td colspan="3">Bracket dimensions <input type="checkbox"/> short <input type="checkbox"/> long</td> </tr> </tbody> </table>	Size (cm)	XS	S	M	W _{RH}	W _{LH}	H	8	10	12			L	14	16	19			Side	Pad Shape	Bracket Type	Bracket Shape	Size	RH	<input type="checkbox"/> linear <input type="checkbox"/> armpit cut	<input type="checkbox"/> fixed <input type="checkbox"/> detachable <input type="checkbox"/> swing-away	<input type="checkbox"/> A <input type="checkbox"/> B <input type="checkbox"/> C <input type="checkbox"/> D		<input type="checkbox"/> linear <input type="checkbox"/> armpit cut	<input type="checkbox"/> fixed <input type="checkbox"/> detachable <input type="checkbox"/> swing-away	<input type="checkbox"/> A <input type="checkbox"/> B <input type="checkbox"/> C <input type="checkbox"/> D		Bracket padding <input type="checkbox"/> RH <input type="checkbox"/> LH		Bracket dimensions <input type="checkbox"/> short <input type="checkbox"/> long		
Size (cm)	XS	S	M	L	W _{RH}	W _{LH}																																																																								
H	8	10	12	12																																																																										
L	10	12	15	18																																																																										
Side	Pad Shape	Bracket Type	Bracket Shape	Size																																																																										
RH	<input type="checkbox"/> linear <input type="checkbox"/> armpit cut	<input type="checkbox"/> fixed <input type="checkbox"/> detachable <input type="checkbox"/> swing-away	<input type="checkbox"/> A <input type="checkbox"/> B <input type="checkbox"/> C <input type="checkbox"/> D																																																																											
	<input type="checkbox"/> linear <input type="checkbox"/> armpit cut	<input type="checkbox"/> fixed <input type="checkbox"/> detachable <input type="checkbox"/> swing-away	<input type="checkbox"/> A <input type="checkbox"/> B <input type="checkbox"/> C <input type="checkbox"/> D																																																																											
Bracket padding <input type="checkbox"/> RH <input type="checkbox"/> LH		Bracket dimensions <input type="checkbox"/> short <input type="checkbox"/> long																																																																												
Size (cm)	XS	S	M	W _{RH}	W _{LH}																																																																									
H	8	10	12																																																																											
L	14	16	19																																																																											
Side	Pad Shape	Bracket Type	Bracket Shape	Size																																																																										
RH	<input type="checkbox"/> linear <input type="checkbox"/> armpit cut	<input type="checkbox"/> fixed <input type="checkbox"/> detachable <input type="checkbox"/> swing-away	<input type="checkbox"/> A <input type="checkbox"/> B <input type="checkbox"/> C <input type="checkbox"/> D																																																																											
	<input type="checkbox"/> linear <input type="checkbox"/> armpit cut	<input type="checkbox"/> fixed <input type="checkbox"/> detachable <input type="checkbox"/> swing-away	<input type="checkbox"/> A <input type="checkbox"/> B <input type="checkbox"/> C <input type="checkbox"/> D																																																																											
Bracket padding <input type="checkbox"/> RH <input type="checkbox"/> LH		Bracket dimensions <input type="checkbox"/> short <input type="checkbox"/> long																																																																												

Note.: If the type of bracket is not indicated, the **fixed short bracket** will be supplied

Hip Guides

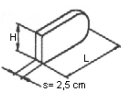
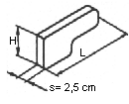
<input type="checkbox"/> Linear hip guide  <table border="1" style="width: 100%; border-collapse: collapse;"> <thead> <tr> <th>Size (cm)</th> <th>XS</th> <th>S</th> <th>M</th> <th>L</th> <th>W_{RH}</th> <th>W_{LH}</th> </tr> </thead> <tbody> <tr> <td>H</td> <td>8</td> <td>10</td> <td>10</td> <td>12</td> <td></td> <td></td> </tr> <tr> <td>L</td> <td>22</td> <td>25</td> <td>30</td> <td>35</td> <td></td> <td></td> </tr> </tbody> </table> <table border="1" style="width: 100%; border-collapse: collapse;"> <thead> <tr> <th>Side</th> <th>Bracket Type</th> <th>Bracket Shape</th> <th>Pad size</th> </tr> </thead> <tbody> <tr> <td rowspan="2">RH</td> <td><input type="checkbox"/> fixed <input type="checkbox"/> detachable</td> <td><input type="checkbox"/> A <input type="checkbox"/> B <input type="checkbox"/> C <input type="checkbox"/> D</td> <td></td> </tr> <tr> <td><input type="checkbox"/> fixed <input type="checkbox"/> detachable</td> <td><input type="checkbox"/> A <input type="checkbox"/> B <input type="checkbox"/> C <input type="checkbox"/> D</td> <td></td> </tr> <tr> <td colspan="2">Bracket padding <input type="checkbox"/> RH <input type="checkbox"/> LH</td> <td colspan="2">Additional Bracket <input type="checkbox"/> RH <input type="checkbox"/> LH</td> </tr> </tbody> </table>	Size (cm)	XS	S	M	L	W _{RH}	W _{LH}	H	8	10	10	12			L	22	25	30	35			Side	Bracket Type	Bracket Shape	Pad size	RH	<input type="checkbox"/> fixed <input type="checkbox"/> detachable	<input type="checkbox"/> A <input type="checkbox"/> B <input type="checkbox"/> C <input type="checkbox"/> D		<input type="checkbox"/> fixed <input type="checkbox"/> detachable	<input type="checkbox"/> A <input type="checkbox"/> B <input type="checkbox"/> C <input type="checkbox"/> D		Bracket padding <input type="checkbox"/> RH <input type="checkbox"/> LH		Additional Bracket <input type="checkbox"/> RH <input type="checkbox"/> LH		<input type="checkbox"/> Contoured hip guide  <table border="1" style="width: 100%; border-collapse: collapse;"> <thead> <tr> <th>Size (cm)</th> <th>XS</th> <th>S</th> <th>M</th> <th>L</th> <th>W_{RH}</th> <th>W_{LH}</th> </tr> </thead> <tbody> <tr> <td>H</td> <td>8</td> <td>10</td> <td>10</td> <td>12</td> <td></td> <td></td> </tr> <tr> <td>L</td> <td>22</td> <td>25</td> <td>30</td> <td>35</td> <td></td> <td></td> </tr> </tbody> </table> <table border="1" style="width: 100%; border-collapse: collapse;"> <thead> <tr> <th>Side</th> <th>Bracket Type</th> <th>Bracket Shape</th> <th>Pad size</th> </tr> </thead> <tbody> <tr> <td rowspan="2">RH</td> <td><input type="checkbox"/> fixed <input type="checkbox"/> detachable</td> <td><input type="checkbox"/> A <input type="checkbox"/> B <input type="checkbox"/> C <input type="checkbox"/> D</td> <td></td> </tr> <tr> <td><input type="checkbox"/> fixed <input type="checkbox"/> detachable</td> <td><input type="checkbox"/> A <input type="checkbox"/> B <input type="checkbox"/> C <input type="checkbox"/> D</td> <td></td> </tr> <tr> <td colspan="2">Bracket padding <input type="checkbox"/> RH <input type="checkbox"/> LH</td> <td colspan="2">Additional Bracket <input type="checkbox"/> RH <input type="checkbox"/> LH</td> </tr> </tbody> </table>	Size (cm)	XS	S	M	L	W _{RH}	W _{LH}	H	8	10	10	12			L	22	25	30	35			Side	Bracket Type	Bracket Shape	Pad size	RH	<input type="checkbox"/> fixed <input type="checkbox"/> detachable	<input type="checkbox"/> A <input type="checkbox"/> B <input type="checkbox"/> C <input type="checkbox"/> D		<input type="checkbox"/> fixed <input type="checkbox"/> detachable	<input type="checkbox"/> A <input type="checkbox"/> B <input type="checkbox"/> C <input type="checkbox"/> D		Bracket padding <input type="checkbox"/> RH <input type="checkbox"/> LH		Additional Bracket <input type="checkbox"/> RH <input type="checkbox"/> LH	
Size (cm)	XS	S	M	L	W _{RH}	W _{LH}																																																																			
H	8	10	10	12																																																																					
L	22	25	30	35																																																																					
Side	Bracket Type	Bracket Shape	Pad size																																																																						
RH	<input type="checkbox"/> fixed <input type="checkbox"/> detachable	<input type="checkbox"/> A <input type="checkbox"/> B <input type="checkbox"/> C <input type="checkbox"/> D																																																																							
	<input type="checkbox"/> fixed <input type="checkbox"/> detachable	<input type="checkbox"/> A <input type="checkbox"/> B <input type="checkbox"/> C <input type="checkbox"/> D																																																																							
Bracket padding <input type="checkbox"/> RH <input type="checkbox"/> LH		Additional Bracket <input type="checkbox"/> RH <input type="checkbox"/> LH																																																																							
Size (cm)	XS	S	M	L	W _{RH}	W _{LH}																																																																			
H	8	10	10	12																																																																					
L	22	25	30	35																																																																					
Side	Bracket Type	Bracket Shape	Pad size																																																																						
RH	<input type="checkbox"/> fixed <input type="checkbox"/> detachable	<input type="checkbox"/> A <input type="checkbox"/> B <input type="checkbox"/> C <input type="checkbox"/> D																																																																							
	<input type="checkbox"/> fixed <input type="checkbox"/> detachable	<input type="checkbox"/> A <input type="checkbox"/> B <input type="checkbox"/> C <input type="checkbox"/> D																																																																							
Bracket padding <input type="checkbox"/> RH <input type="checkbox"/> LH		Additional Bracket <input type="checkbox"/> RH <input type="checkbox"/> LH																																																																							

Note: If the type of bracket is not reported the **fixed bracket** will be supplied.

The shape of the bracket: allows variations of the seat and/or backrest width

- A L 90° bracket allows a reduction of the width up to 2.5 cm per side
- B 2.5 cm Offset bracket allows a reduction of the width up to 5 cm per side
- C 5 cm Offset bracket allows a reduction of the width up to 7.5 cm per side
- D Reverse bracket doesn't allow any variation

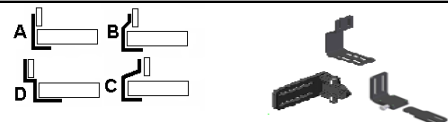



Note: in the removable/fixed version the difference between the short and the long bracket is about 2cm in length, in the swing-away version is about 5cm

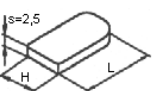
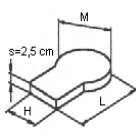

Arm supports (only in combination with the Hip Guides)

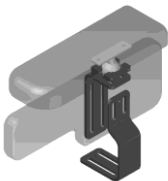
<input type="checkbox"/> Flat								<input type="checkbox"/> Flat and shaped											
		Size (cm)		XS	S	M	L	W _{RH}	W _{LH}			Size (cm)		XS	S	M	L	W _{RH}	W _{LH}
		H		8	10	10	12					H		8	10	10	12		
		L		22	25	30	35					L		30	35	40	48		
Side	Flat	Flat contoured						Size		Side	Shaped flat	Shaped contoured						Size	
RH	<input type="checkbox"/> linear	<input type="checkbox"/> inside contoured <input type="checkbox"/> outside contoured <input type="checkbox"/> posterior contoured								RH	<input type="checkbox"/> palmar <input type="checkbox"/> elbow	<input type="checkbox"/> palmar <input type="checkbox"/> elbow <input type="checkbox"/> inside contoured <input type="checkbox"/> outside contoured <input type="checkbox"/> posterior contoured							
LH	<input type="checkbox"/> linear	<input type="checkbox"/> inside contoured <input type="checkbox"/> outside contoured <input type="checkbox"/> posterior contoured								LH	<input type="checkbox"/> palmar <input type="checkbox"/> elbow	<input type="checkbox"/> palmar <input type="checkbox"/> elbow <input type="checkbox"/> inside contoured <input type="checkbox"/> outside contoured <input type="checkbox"/> posterior contoured							
Arm straps		<input type="checkbox"/> RH	<input type="checkbox"/> not padded	<input type="checkbox"/> padded	q.ty _____				<input type="checkbox"/> LH	<input type="checkbox"/> not padded	<input type="checkbox"/> padded	q.ty _____							

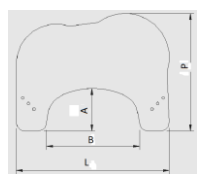
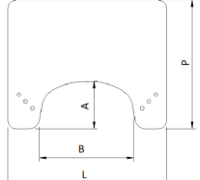

Mounting System for Hip Guides/Arm Support

<input type="checkbox"/> with multiaxial sphere  <div style="text-align: right;"> Side <input type="checkbox"/> RH <input type="checkbox"/> LH </div>	<input type="checkbox"/> with "L" bracket  <div style="text-align: right;"> Side <input type="checkbox"/> RH <input type="checkbox"/> LH </div>
--	---

Trays

<input type="checkbox"/> ergonomic wooden tray					<input type="checkbox"/> rectangular wooden tray						
	Size (cm)	<input type="checkbox"/> US	<input type="checkbox"/> P	<input type="checkbox"/> M	<input type="checkbox"/> G		Size (cm)	<input type="checkbox"/> US	<input type="checkbox"/> P	<input type="checkbox"/> M	<input type="checkbox"/> G
	P	47	53	58	66		P	45	50	55	63
	L	58	69	75	86		L	56	66	71	82
	B	35	42	49	55		B	35	42	48	55
	A	17	19	21	24		A	17	19	21	24
<input type="checkbox"/> with lateral flip hardware					<input type="checkbox"/> with detachable hardware w/brackets						
											
Padding					Outer edge						
<input type="checkbox"/> blue leather flex <input type="checkbox"/> black leather flex					<input type="checkbox"/> yes <input type="checkbox"/> no						

Abductor wedge

	Size (cm)	<input type="checkbox"/> S	<input type="checkbox"/> M	<input type="checkbox"/> L	<input type="checkbox"/> W	Note: To be combined only with flat padding, wedge padding, anti-thrust padding and anti-thrust with adductors
	H	7.5	9	10		
	D	9	10	11.5		
	L	7.5	9	10		
<input type="checkbox"/> removable with lever 		<input type="checkbox"/> removable mounting block 				
Please indicate the position of holes under the seat (if not indicated the abductor wedge will be fixed in the standard position)						
<input type="checkbox"/> standard <input type="checkbox"/> not centred						
<input type="checkbox"/> on the RH <input type="checkbox"/> on the LH						

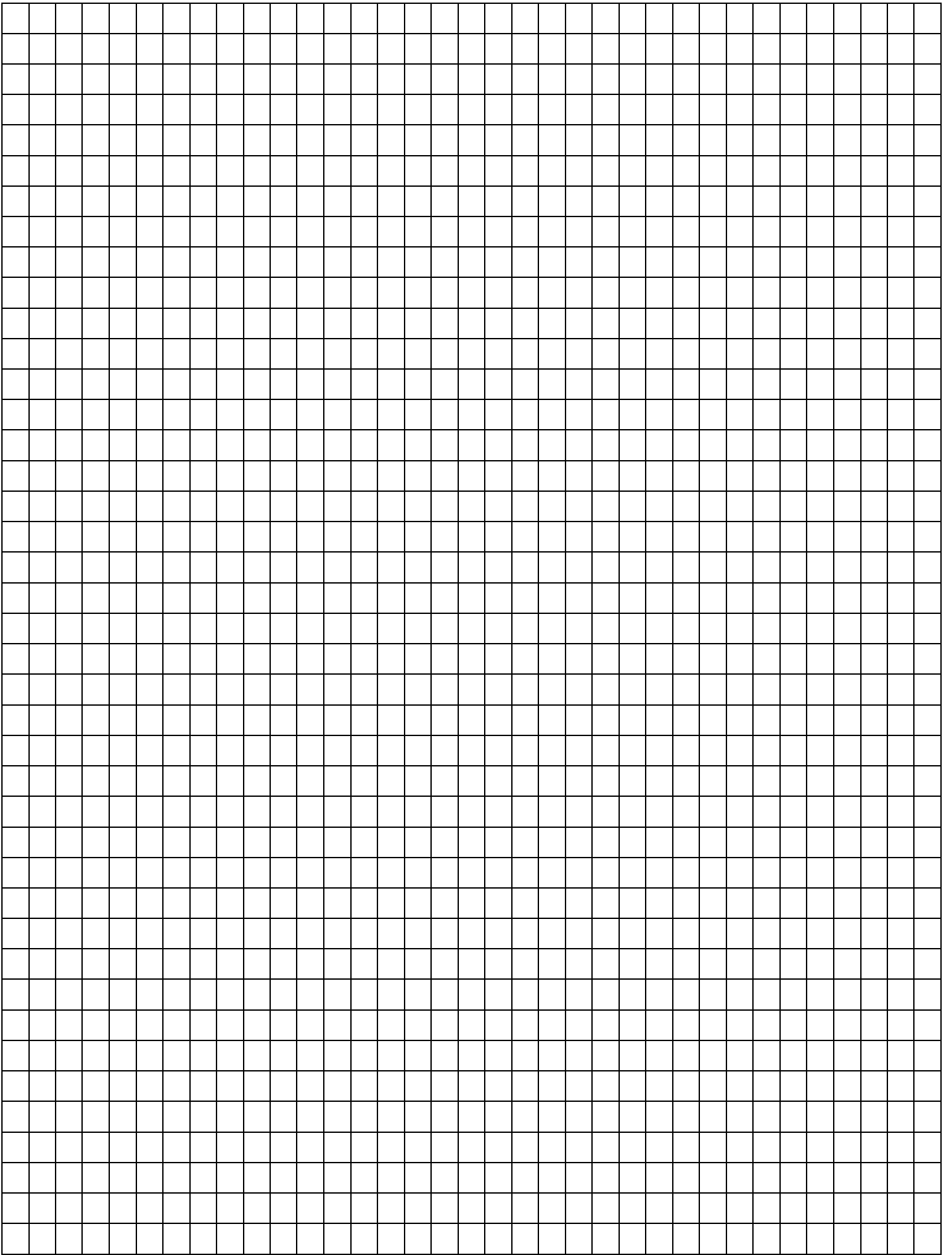

PRO MEDICARE S.r.l.
Via Montagna Z.I. Lotto 41-72023 Mesagne (Br)-ITALY
Tel: +39-0831-777840
Website: www.promedicare.eu e-mail: sales@promedicare.it